

DMC Co., Ltd.

**Analog Resistive Touch Screen Controller
TSC-30/IC product specification**

Table of Contents

1. Products outline	2
1-1. Scope of Application	2
1-2. Outline	2
1-3. Features	2
1-4. General specification	3
2. Pin layout and representation	4
3. Pin functions	5
4. Initial setting	7
4-1. EEPROM setting	7
4-2. Communication mode setting	7
4-3. Touch screen mode setting	7
4-4. Configuration in USB mode	8
4-5. Panel ID setting (USB mode)	8
5. Data sheet	9
5-1. Absolute maximum rating	9
5-2. Recommended operational conditions	10
5-3. Timing requirement	12
5-4. DC standards	14
6. Packaging Specification	16
6-1. Outline	16
6-2. Notes on storage/handling	16
6-3. Basic packaging	16
6-4. Small group packaging	17
6-5. Tray specification	18
6-6. Product name label specification	18
7. Storage Specification	19
7-1. Storage Conditions	19
7-2. Baking	19
8. Implementation Temperature Specification	20
9. Terminal Pin Specification	21
10. Cleaning	21
11. Changes and improvements	22
11-1. Version history	22
12. Warranty	23
12-1. Warranty Period	23
12-2. Warranty Target	23
12-3. Warranty Exceptions	23
13. Notes on use	24
13-1. Overall handling	24
13-2. Others	24

Dimensional Drawing

Circuit Diagram

1. Products outline

1-1. Scope of Application

This specification applies to the TSC-30/IC.

1-2. Outline

TSC-30/IC is an analog touch screen control IC that performs A/D conversion on analog signal for the 4-wire, 5-wire and 8-wire resistive analog touch screen, and transmits coordination data with 10bit resolution to the host in a 9600bps serial (asynchronous) and USB.

At the coordinate detection, internal filtering process provides a stabilized coordinate value. By using the correction function, in addition to the losses that occur in the circuit, display deflection between touch screen input point that occur in each element and indicator cursor can be corrected to adjust the display position.

1-3. Features

- § Two coordinate output modes are provided and selected per application: "Coordinate data mode" where coordinate information is sent with 10bit resolution as it is, and "correction data mode" where read coordinate is converted to the indicator's display coordinate and sent.
- § "Correction data mode" is available after EEPROM is externally attached. It enables to set up to nine correction points. Coordinate data can be corrected with the base of correction points. Using this function allows the host driver to make the implementation of correction function unnecessary. In addition, by placing correction points at the touch screen center and center points of four edges of touch screen, resistance value deviation of transparent electrode film can be corrected.
- § USB has multi-touch screen function enable two simultaneous connections to the host.
- § Two external switch functions are always available in the coordinate (correction) data mode. Two pieces of external switch information are, at the transmission of coordinate data, included in the coordinate data as pen-down/pen-up information. Since in the pen-up mode, pen-up data can be always output to the host, this switch is available as a function switch.
- § At the touch screen input, buzzer and LED outputs are available. Input confirmation via display and sound is available.
- § In the serial communication, when no touch screen input is performed, the state moves to "power-save mode" so that such application can be supported that requests a low power consumption. In USB mode, USB suspend is supported and restored by the external interrupt of touch screen input.
- § Seven types of coordinate output rates are provided and either can be selected per application among seven types: six types from 30 to 150p/s plus one type, a point mode that outputs the coordinate only one time when pen-down is performed.

1-4. General specification

Item		Rating	Notes
Power supply voltage		DC 3.00V to 5.25V	
Power consumption		125mW (standard)	Power supply voltage is 5V.
		30mW (standard)	Power supply voltage is 3.3V.
Operating Temp	Asynchronous serial	-20 °C to +85 °C (No dew condensation)	
	USB	0 °C to +70 °C (No dew condensation)	
Temperature range at storing		-40 °C to +125 °C (No dew condensation)	
Communication scheme (serial)	Communication scheme	Asynchronous, serial	Each setting is fixed
	Communication rate	9600bps	
	Data length	8bits	
	Stop bit	1bit	
	Parity	None	
Communication scheme (USB)	Transfer rate	USB Specification2.0 Full Speed	
	Transfer mode	Control transfer (command)	
		Interrupt transfer (coordinate)	
Operation frequency		6MHz	Fixed to 6MHz
Coordinate output rate (point / second)		(1) Point mode (2) 30p/s (3) 50p/s (4) 80p/s (5) 100p/s (6) 130p/s (7) 150p/s	Point Mode: Only when touch screen is input, pen-down ID is sent once. After input ends, no pen-up ID is sent.
Linearity error		±3 LSB	
Input response time		10ms (TYP)	For coordinate mode, 150p/s, Serial mode
Coordinate resolution		10bit (1024×1024)	In the correction data function, resolution follows the setting value
Dimension (mm)		12×12×1.7	

2. Pin layout and representation

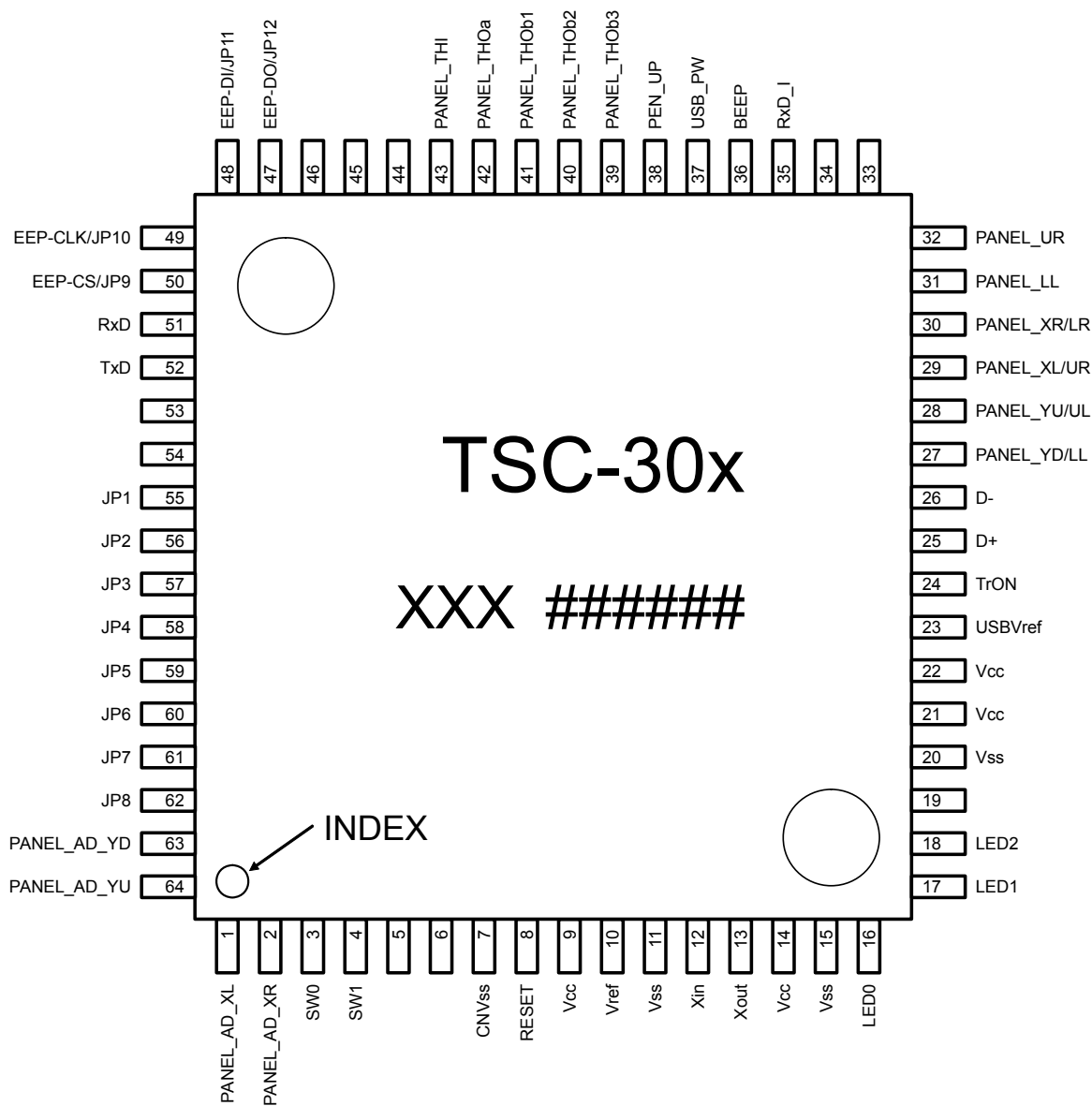

Marking specification

TSC-30x Product number x: version number
 xxx ROM number
 ##### Lot number

3. Pin functions

Pin number	Pin name	I/O	Functional description
1	PANEL_AD_XL	I	Touch Screen XL input pin.
2	PANEL_AD_XR	I	Touch Screen XR input pin.
3	SW0	I	SW0 input pin; H=ON=1, L=OFF=0.
4	SW1	I	SW1 input pin; H=ON=1, L=OFF=0.
5		I	Unused pin. Via resistance; Vcc is connected.
6		I	Unused pin. Via resistance; Vcc is connected.
7	CNVss	P	Vss is connected.
8	RESET	I	Reset input pin (active L).
9	Vcc	P	Power supply input pin; Vcc is connected.
10	Vref	P	A/D converter reference voltage input pin; Vcc is connected.
11	Vss	P	Power supply input pin (GND); GND is connected.
12	Xin	I	Clock input pin; When using external clock, clock is input to this pin.
13	Xout	O	Clock output pin; When using external clock, this pin is opened.
14	Vcc	P	Power supply input pin; Vcc is connected.
15	Vss	P	Power supply input pin (GND); GND is connected.
16	LED0	O	LED output pin; When internal initialization was finished correctly, output L.
17	LED1	O	LED output pin; Touch input, ON=L, OFF=H.
18	LED2	O	LED output pin; When a response for the command is NAK, output L.
19		O	Unused pin; Opened.
20	Vss	P	Power supply input pin (GND); GND is connected.
21	Vcc	P	Power supply input pin; Vcc is connected.
22	Vcc	P	Power supply input pin; Vcc is connected.
23	USBVref	P	USB reference voltage input pin. If Vcc is 3.3V, Vcc is connected. If Vcc is 5V, GND is connected via capacitor.
24	TrON	O	Identification signal for USB. D+ is connected via resistance (1.5k ohm).
25	D+	I/O	Data send/receive pin; In USB mode, D+ pin. In serial mode, GND is connected via resistance (1k to 10k ohm).
26	D-	I/O	Data send/receive pin; In USB mode, D- pin. In serial mode, GND is connected via resistance (1k to 10k ohm).
27	PANEL_YD/LL	O	Touch screen control pin.
28	PANEL_YU/UL	O	Touch screen control pin.
29	PANEL_XL/UR	O	Touch screen control pin.
30	PANEL_XR/LR	O	Touch screen control pin.
31	PANEL_LL	O	Touch screen control pin. Used only in 5-wire mode. In 4-wire/8-wire mode, opened.
32	PANEL_UR	O	Touch screen control pin. Used only in 5-wire mode. In 4-wire/8-wire mode, opened.
33		O	Unused pin; Opened.
34		O	Unused pin; Opened.
35	RxD_I	I	In power-save mode, start signal input pin by command reception. Only used serial communication mode.
36	BEEP	O	BEEP output pin; H output.
37	USB_PW	I	USB power supply detection pin. In USB mode, USB-Vbus is connected. *1 In serial mode, GND is connected.
38	PEN_UP	I	GND is connected.
39	PANEL_THOb3	I/O	Touch screen control pin. Used only in 5-wire mode. In 4-wire/8-wire mode, opened.

40	PANEL_THOb2	I/O	Touch screen control pin. Used only in 5-wire mode. In 4-wire/8-wire mode, opened.
41	PANEL_THOb1	I/O	Touch screen control pin. Used only in 5-wire mode. In 4-wire /8-wire mode, opened.
42	PANEL_THOa	I/O	Pen down detection pin.
43	PANEL_THI	I	In power-save mode, start signal input pin by pen down.
44		O	Unused pin; Opened.
45		O	Unused pin; Opened.
46		O	Unused pin; Opened.
47	EEP-DO/JP12	I/O	Vcc is connected. When using EEPROM, EEPROM DO is connected.
48	EEP-DI/JP11	I/O	When using EEPROM, EEPROM DI is connected. When not using EEPROM, Vcc is connected via resistance.
49	EEP-CLK/JP10	I/O	When using EEPROM, EEPROM SK is connected. When not using EEPROM, Vcc is connected via resistance.
50	EEP-CS/JP9	I/O	EEPROM setting pin shared with EEPROM CS signal output pin. EEPROM is set via resistance and Vcc or GND is connected. (L=Used, H=Not used) When using EEPROM, EEPROM CS is connected.
51	RxD	I	In serial mode, data receive pin. In USB mode, Vcc is connected via resistance.
52	TxD	O	In serial mode, data send pin. In USB mode, opened.
53		O	Unused pin; Opened.
54		O	Unused pin; Opened.
55	JP1	I	GND is connected.
56	JP2	I	GND is connected.
57	JP3	I	GND is connected.
58	JP4	I	Panel ID select pin.
59	JP5	I	Panel ID select pin.
60	JP6	I	Touch screen mode setting pin; L=4 / 8 wire, H=5-wire
61	JP7	I	Touch screen mode setting pin; L=4 / 5 wire, H=8-wire
62	JP8	I	In USB mode, if Vcc is 5V, Vcc is connected via resistance. If Vcc is 3.3V, GND is connected. In serial mode, Vcc is connected via resistance or GND is connected.
63	PANEL_AD_YD	I	Touch Screen YD input pin.
64	PANEL_AD_YU	I	Touch Screen YU input pin.

*1: Please be careful if you use a external power supply not to exceed the power supply voltage in this terminal.

4. Initial setting

4-1. EEPROM setting

Depending on that calibration is performed in either TSC-30/IC or host, you can select whether EEPROM is used or not to store the correction data. EEPROM selection can be set via pin number 50, where hardware reset release enables the setting.

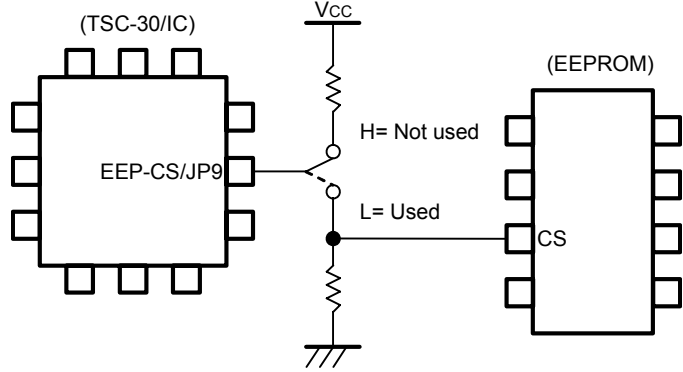

4-2. Communication mode setting

Communication mode setting for serial/USB is performed by setting pin number 37 to “H” or “L”. When power supply is turned on, or hardware reset is released, pin number 37 is read to turn on in either USB/serial mode.

No both communication schemes are used at a time. After the hardware reset, if setting is performed with jumper switch, the setting is enabled by power supply restart or hardware reset.

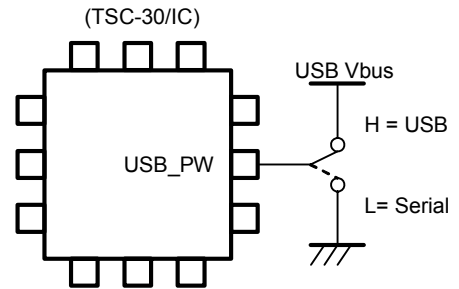

4-3. Touch screen mode setting

Touch screen mode setting for 4-wire, 5-wire or 8-wire is performed by setting pin number 60 and 61 to “H” or “L”. When power supply is turned on, or hardware reset is released, pin number 60 and 61 are read to turn on in either 4-wire, 5-wire or 8-wire mode.

Mode	Pin number 60	Pin number 61
4-wire touch screen	GND	GND
5-wire touch screen	Vcc	GND
8-wire touch screen	GND	Vcc

4-4. Configuration in USB mode

§ Basic configuration

Item	Specification
USB standard	Specification Rev2.0 Full Speed
Power supply	Bus power supply / Self-Power
Device class	Vendor definition
Interrupt (coordinate) transfer interval	1ms
End point buffer size	EP0: 8byte EP1: 5byte (EP0: control transfer, EP1: interrupt transfer)

§ Connection with Host

Coordinate data, correction value or other various output data are all output to the host as a response to IN token. Output coordinate in coordinate data mode and correction data mode is output in the interrupt transfer, while other data is output to the host with control transfer.

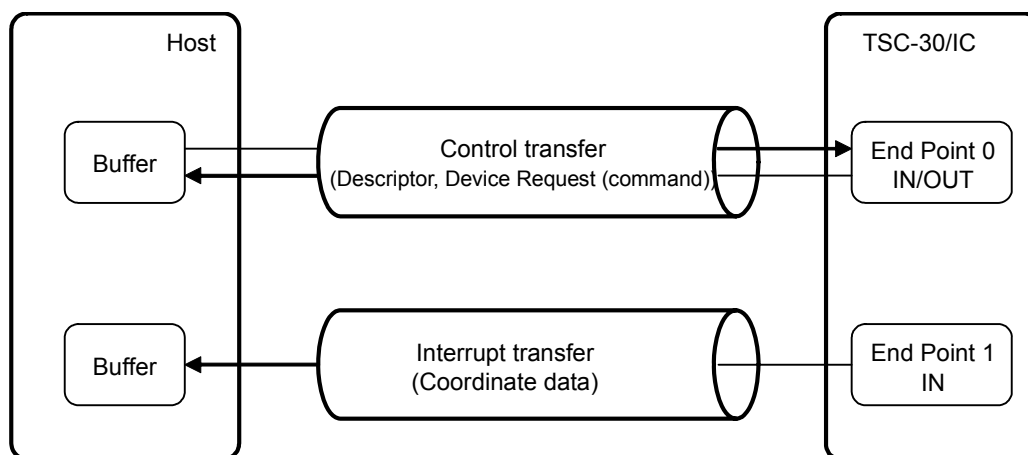

4-5. Panel ID setting (USB mode)

If two (three or four) touch screens to the same host are connected simultaneously, each TSC-30/IC to the host needs panel ID setting. This function is enabled in the USB mode, by setting pin number 58 (JP4) and pin number 59 (JP5) to "H" or "L". Setting is enabled when hardware is reset, where Device Descriptor's iProduct is set to "0" or "1" and this value is identified by the host as panel ID.

JP4	JP5	iProduct	Panel ID
L	L	00h	0
H	L	01h	1
L	H	02h	2
H	H	03h	3

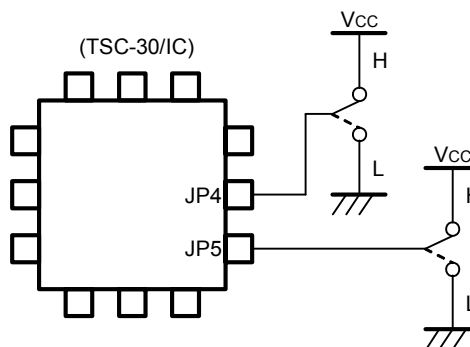

5. Data sheet

5-1. Absolute maximum rating

Item	Symbol	Rating		Unit	Description
		Minimum	Maximum		
Power supply voltage	V _{CC}	-0.3	6.5	V	
Input voltage	V _I	-0.3	V _{CC} +0.3	V	
Output voltage	V _O	-0.3	V _{CC} +0.3	V	
Power consumption	P _D		500	mW	T _a =25°C
Operation temperature	T _{OPR}	-20	+85	°C	
Storage temperature	T _{STG}	-40	+125	°C	

5-2. Recommended operational conditions

Item	Symbol	Rating			Unit	Description
		Minimum	Standard	Maximum		
Power supply voltage	Vcc	3.00	5.00	5.25	V	
Analog reference voltage	AVcc		Vcc		V	
Analog reference voltage	AVREF	2.0		Vcc	V	
Analog reference voltage USB	USBVREF	3.0		3.6	V	Vcc=3.6 to 4.0V
		3.0		Vcc	V	Vcc=3.0 to 3.6V
Power supply voltage	Vss		0		V	
Analog reference voltage	AVss		0		V	
"H" input voltage (Pin number 16-19, 27-50)	V _{IH}	0.8Vcc		Vcc	V	
"H" input voltage (Pin number 1-6, 51-64)	V _{IH}	0.8Vcc		Vcc	V	
"H" input voltage RESET, XIN, Pin number 7, 15	V _{IH}	0.8Vcc		Vcc	V	
"H" input voltage D+, D-	V _{IH}	2.0		3.6	V	
"L" input voltage (Pin number 16-19, 27-50)	V _{IL}	0		0.2Vcc	V	
"L" input voltage (Pin number 1-6, 51-64)	V _{IL}	0		0.2Vcc	V	
"L" input voltage RESET, XIN, Pin number 7, 15	V _{IL}	0		0.2Vcc	V	
"L" input voltage D+, D-	V _{IL}	0		0.8	V	
"H" output total peak current *1 (Pin number 16-19, 27-50)	ΣI _{OH} (peak)			-80	mA	
"H" output total peak current *1 (Pin number 1-6, 51-64)	ΣI _{OH} (peak)			-80	mA	
"L" output total peak current *1 (Pin number 27-50)	ΣI _{OL} (peak)			80	mA	
"L" output total peak current *1 (Pin number 16-19)	ΣI _{OL} (peak)			80	mA	
"L" output total peak current *1 (Pin number 1-6, 51-64)	ΣI _{OL} (peak)			80	mA	
"H" output total average current*1 (Pin number 16-19, 27-50)	ΣI _{OH} (avg)			-40	mA	
"H" output total average current*1 (Pin number 1-6, 51-64)	ΣI _{OH} (avg)			-40	mA	
"L" output total average current*1 (Pin number 27-50)	ΣI _{OL} (avg)			40	mA	
"L" output total average current*1 (Pin number 16-19)	ΣI _{OL} (avg)			40	mA	
"L" output total average current *1 (pin number 1-6, 51-64)	ΣI _{OL} (avg)			40	mA	
"H" output peak current *2 (Pin number 16-19, 27-50)	I _{OH} (peak)			-10	mA	
"H" output peak current *2 (Pin number 1-6, 51-64)	I _{OH} (peak)			-10	mA	

"L" output peak current *2 (Pin number 27-50)	IoH (peak)			10	mA	
"L" output peak current *2 (Pin number 16-19)	IoH (peak)			20	mA	
"L" output peak current *2 (Pin number 1-6, 51-64)	IoH (peak)			10	mA	
"H" output average current *3 (Pin number 16-19, 27-50)	IoH (avg)			-5	mA	
"H" output average current *3 (Pin number 1-6, 51-64)	IoH (avg)			-5	mA	
"L" output average current *3 (Pin number 27-50)	IoL (avg)			5	mA	
"L" output average current *3 (Pin number 16-19)	IoL (avg)			10	mA	
"L" output average current *3 (Pin number 1-6, 51-64)	IoL (avg)			5	mA	
Vibration frequency *4	XIN			6.0	MHz	In USB mode Tolerance:±0.25%

*1 The total peak output current is the absolute value of the peak currents flowing through all the applicable ports. The total average output current is the average value of the absolute value of the currents measured over 100ms flowing through all the applicable ports.

*2 The peak output current is the absolute value of the peak current flowing in each port.

*3 The average output current is the average value of the absolute value of the currents measured over 100ms.

*4 The duty of oscillation frequency is 50%.

5-3. Timing requirement

§ Reset

(Vcc = 3.0 to 5.25V , Vss = 0V , Ta = -20 to 85°C)

Item	Symbol	Rating		Unit	Description
		Minimum	Maximum		
RESET L width	tw	2		μs	

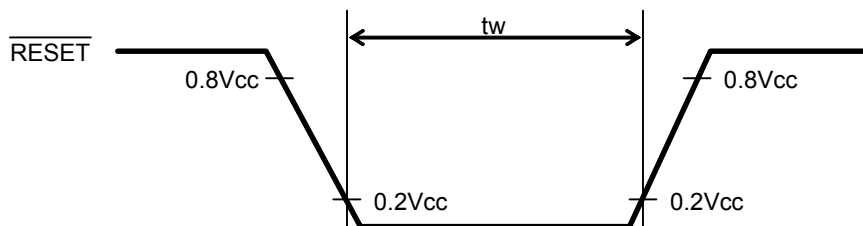

§ Power-on reset

Reset input voltage shall be 0.6V or below at the timing when power supply voltage crosses 3.0V.

(Ta = -20 to 85°C)

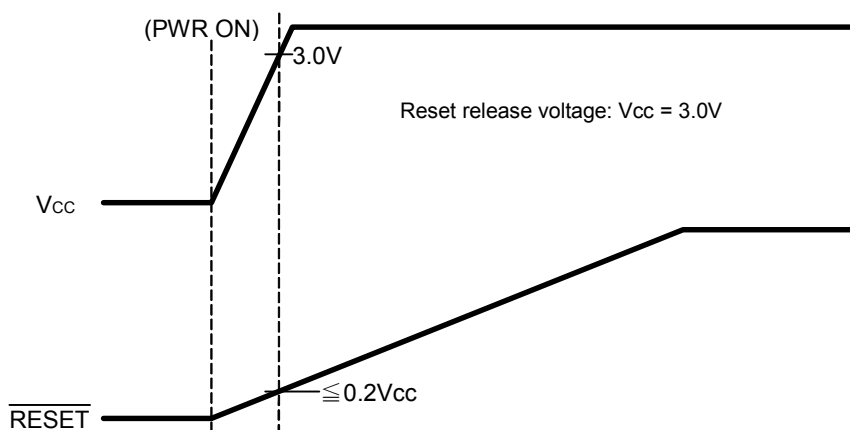

§ External clock timing

Item	Symbol	Rating		Unit	Description
		Minimum	Maximum		
Input cycle	t_c	166		ns	
Clock pulse width	t_{WH}, t_{WL}	70		ns	

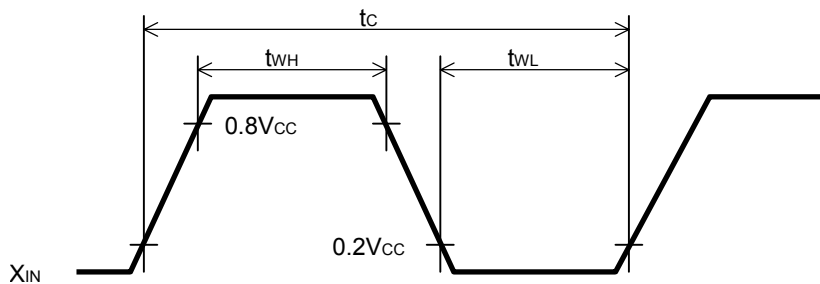

§ Clock input circuit

Using ceramic vibrator

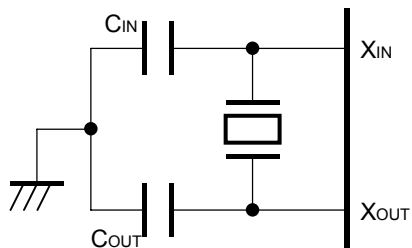

External clock input circuit

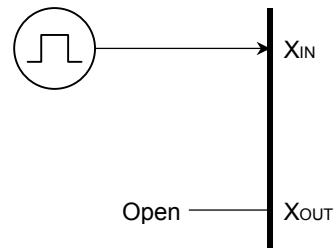

5-4. DC standards

(V_{CC}=3.00 to 5.25V, V_{SS}=0V, T_a=-20 to 85°C, unless otherwise noted)

Item	Symbol	Condition	Rating			Unit
			Minimum	Standard	Maximum	
“H” Output voltage (Pin number 16-19, 27-50)	V _{OH}	IOH = -10mA VCC = 4.0 to 5.25V	V _{CC} -2.0			V
		IOH = -1.0mA	V _{CC} -1.0			
“H” Output voltage (Pin number 1-6, 51-64)	V _{OH}	IOH = -10mA VCC = 4.0 to 5.25V	V _{CC} -2.0			
		IOH = -1mA	V _{CC} -1.0			
“H” Output voltage (Pin number. 25 (D+), 26 (D-))	V _{OH}	Pull-down with 0V via a resistor of 15kΩ±5%	2.8		3.6	V
“L” Output voltage (Pin number 27-50)	V _{OL}	I _{OL} = 10mA VCC = 4.0 to 5.25V			2.0	V
		I _{OL} = 1mA			1.0	
“L” Output voltage (Pin number 16-19)	V _{OL}	I _{OL} = 20mA VCC = 4.0 to 5.25V			2.0	V
		I _{OL} = 1mA			1.0	
“L” Output voltage (Pin number. 25 (D+), 26 (D-))	V _{OL}	Pull-up with 3.6V via a resistor of 15kΩ±5%			0.3	V
“L” Output voltage (Pin number 1-6, 51-64)	V _{OL}	I _{OL} = 10mA VCC = 4.0 to 5.25V			2.0	V
		I _{OL} = 1mA			1.0	
hysteresis (Pin number 35-37)	V _{T+} - V _{T-}			0.6		V
hysteresis (Pin number 1-6, 51-64)	V _{T+} - V _{T-}			0.6		V
hysteresis (Pin number 25(D+), 26(D-))	V _{T+} - V _{T-}			0.25		V
hysteresis (Pin number 8)	V _{T+} - V _{T-}			0.5		V
“H” Input current (Pin number 16-19, 27-50)	I _{IH}	V _I = V _{CC}			5.0	μA
“H” Input current (Pin number 1-6, 51-64)	I _{IH}	V _I = V _{CC}			5.0	μA
“H” Input current (Pin number 7, 8)	I _{IH}	V _I = V _{CC}			5.0	μA
“H” Input current (Pin number 12)	I _{IH}	V _I = V _{CC}		4.0		μA
“L” Input current (Pin number 16-19, 27-50)	I _{IL}	V _I = V _{SS}			-5.0	μA
Input “L” current (Pin number 1-6, 51-64)	I _{IL}	V _I = V _{SS}			-5.0	μA
Input “L” current (Pin number 7, 8, 15)	I _{IL}	V _I = V _{SS}			-5.0	μA
Input “L” current (Pin number 12)	I _{IL}	V _I = V _{SS}		-4.0		μA

Power supply current	Icc1	Normal mode *1	Vcc= 4.0 to 5.25V		2.1	60	mA
			Vcc= 3.0 to 4.0V			35	mA
	Icc2	STOP mode *2	Vcc= 3.0 to 5.25V		2.0		mA
	Icc3	At USB suspend mode*3	Vcc= 4.0 to 5.25V		125.0	250	uA
Vcc= 3.0 to 5.25V				0.1		uA	

*1: All USB difference-input circuits enabled. Leaving I/O pins open. Operating functions: CPU, Timers

*2: All USB difference-input circuits enabled. Leaving I/O pins open. Operating functions: Timers, USB receiving. Disabled functions: CPU.

*3: All USB difference-input circuits disabled. Leaving I/O pins open. Oscillation stopped.

6. Packaging Specification

6-1. Outline

With a basic packaging unit of 800, TSC-30/IC is packaged for the number of 800 and its multiple using damp-proof aluminum laminate bags (Basic packaging). If the delivery quantity is less than 800 or not multiple of 800, or the product can not be packaged with a unit of 800, then no damp-proof packaging specification is applicable (Small group packaging).

If packaged with small group packaging, the products may be dampened. Before packaging, the product shall take the baking process as specified in [Baking] defined in "7. Storage Specification".

6-2. Notes on storage/handling

- (1) Handle the packages with care and avoid throwing and dropping them. Or, a large impact may be imposed, causing packaging material's damage, broken package or bending lead.
- (2) Cardboard box may be deteriorated in its strength and deformed due to storage site's humidity, stacking condition and storage duration. It is desirable to keep the storage under normal temperature/humidity (5 to 35 °C, 45 to 75%RH). For warehousing, follow the FIFO principle.
- (3) After unpacking, be careful in handling the product to avoid electrostatic breakdown.

6-3. Basic packaging

6-3-1. Packaging type

Damp-proof packaging (Aluminum laminate bag)

6-3-2. Packaging quantity specification

Quantity per tray	Number of trays	Quantity per packages
160	5 + 1(cover)	800

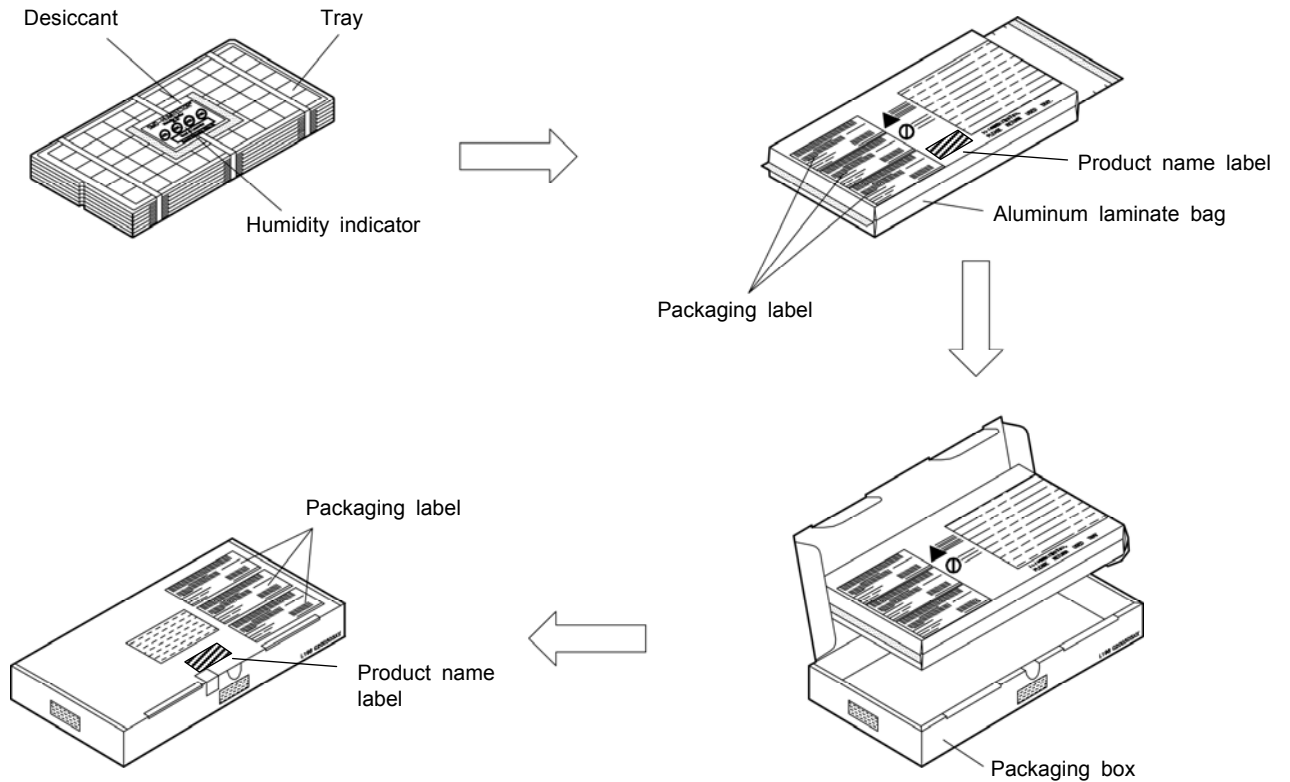

6-3-3. Diagram for packaging box sizes

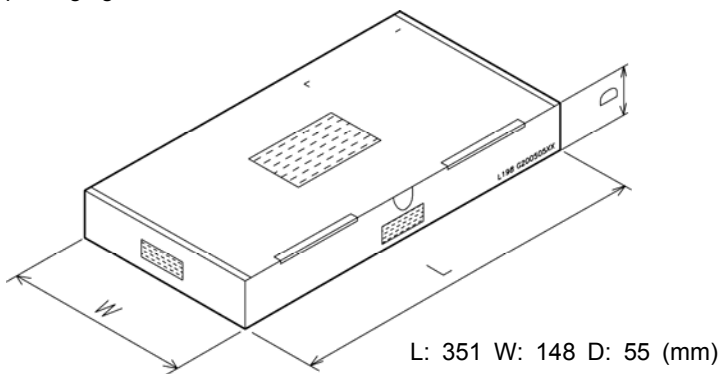

6-4. Small group packaging

6-4-1. Packaging type

General packaging (No damp-proof processing)

6-4-2. Packaging quantity specification

Quantity per tray	Number of trays	Quantity per packages
160	1 - 5 + 1(cover)	1 - 799

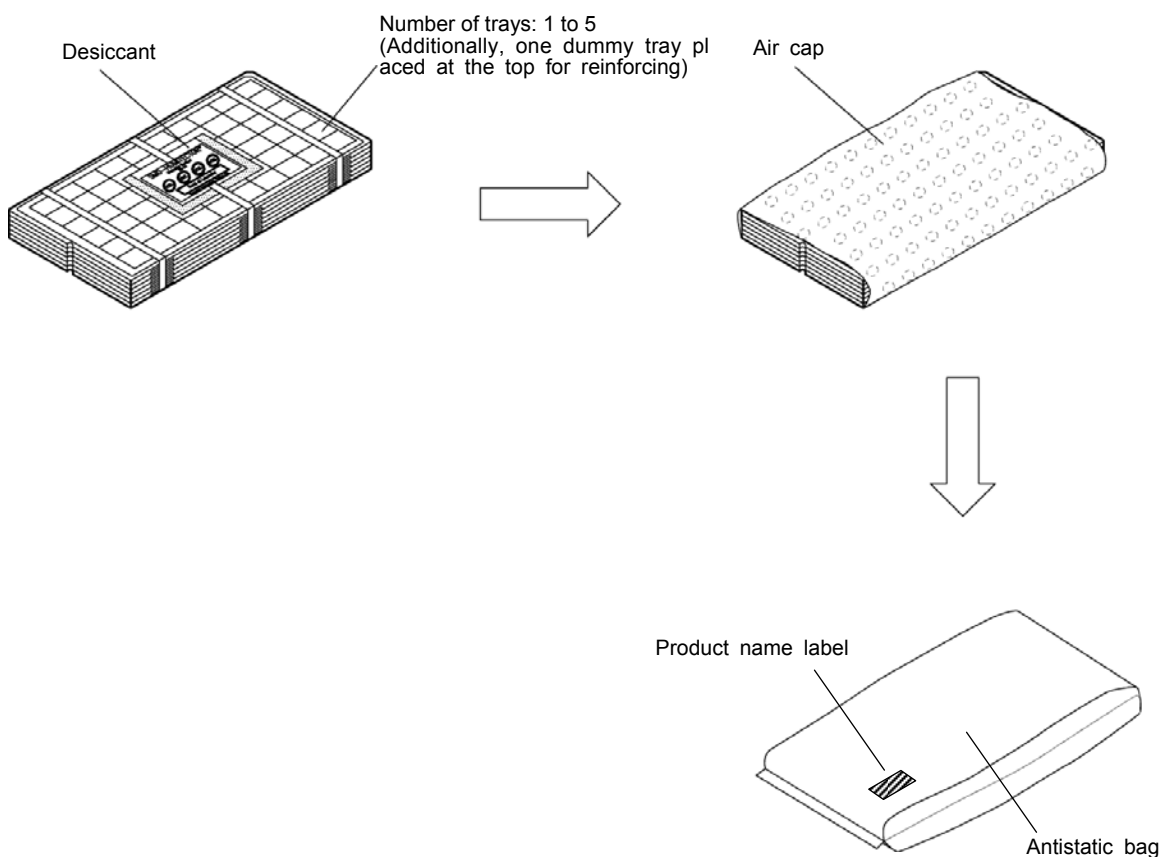

* No sizes specified for packaging box (Cardboard box) used for transportation.

6-5. Tray specification

This tray is heat-proof type, allowing the heating with 125 °C for 24 hours. During heating/cooling process, however, bending may occur. In baking process, to minimize the bending, heat and cool the tray by placing it on a flat plate.

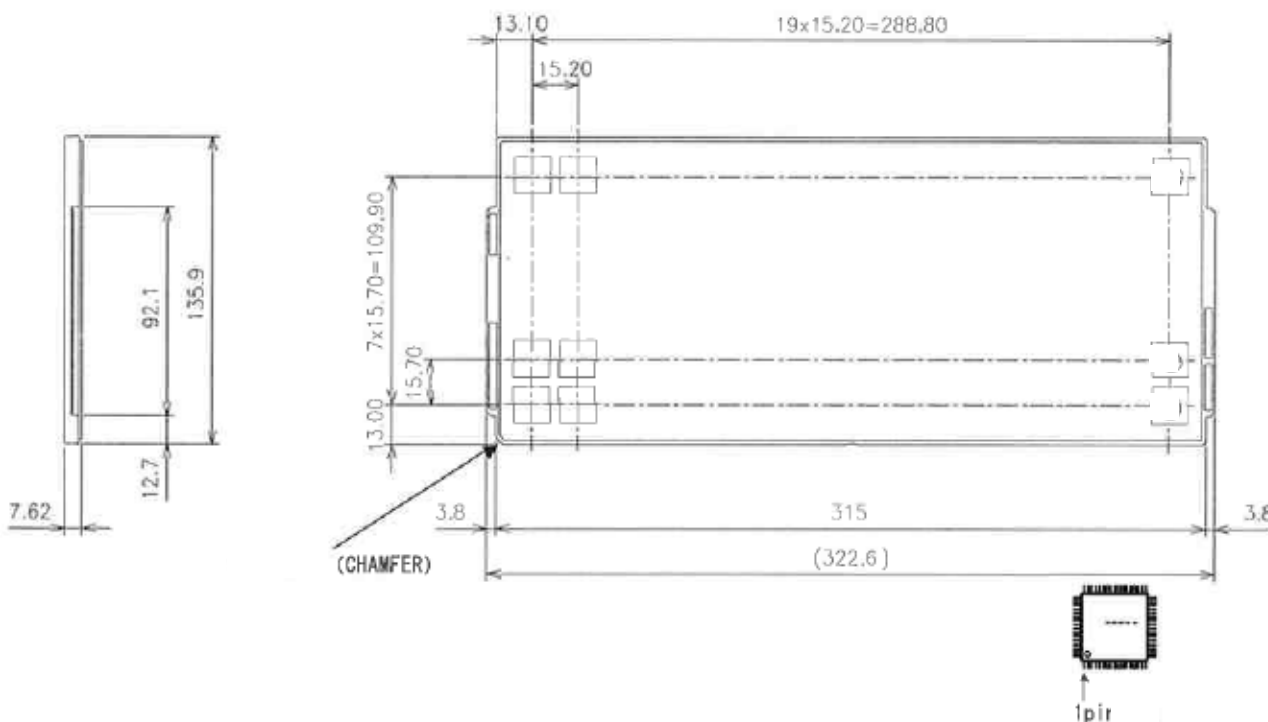

6-6. Product name label specification

- DMC P/N: Product number (TSC-30/IC)
- QTY: Quantity
- DAC: DMC Control Number

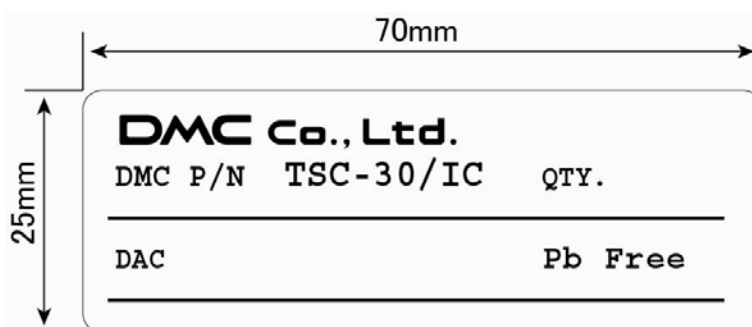

7. Storage Specification

7-1. Storage Conditions

For storing the product until its implementation, it is recommended that the following storage conditions are applied:

1. Before unpacking the damp-proof package (Aluminum laminate bag)
Temperature and humidity: 5 to 40 °C, 20 - 80%RH
Duration: Two years or less
2. After unpacking the damp-proof package (Aluminum laminate bag)
For the storing duration after the damp-proof package is unpacked and before the implementation, it is recommended that the following storage conditions is to be applied:
(1) Reflow method: Two weeks or less under the ambient condition: 30 °C, 70%RH or less
3. Temporary storage after damp-proof package is unpacked
To store again temporarily the once unpacked and unused damp-proof package, it is recommended to pack it again into another damp-proof bag with desiccant within a shorter time after opened (Around 10 minutes) as far as possible, and fold the bag's opening, followed by sealing with adhesive material such as adhesive tape, then store it under the following conditions:
Temperature, humidity: 5 to 40 °C, 20 - 80%RH
Duration: One month or less

7-2. Baking

If any condition among those 1 to 3 listed below is applicable, it is recommended to apply the baking as described below to dry the moisture the package absorbs.

You may place the tray used for damp-proof packaging directly into the thermostatic chamber since the tray is heat-proof type. When placing into the chamber or after removing from it, to avoid deformation, cool the tray by placing it on the flat plate such as surface table.

1. Any condition among 1 to 3 in [7-1. Storage condition] is unsatisfied
2. Indicator's 30% Humidity Check section changes the color to lavender or pink
3. Blue color indicator of desiccant (Silica gel) changes to pink or white

Baking method

- Temperature: 125 °C
Duration: 20 to 24 hours
Frequency: Four times or less (Upper limit: 96 accumulative hours)

8. Implementation Temperature Specification

We do not recommend the wave soldering method.

1. Reflow method (Infrared reflow, air reflow)

Frequency: Three times or less

Temperature: The following device surface temperature profile is recommended.

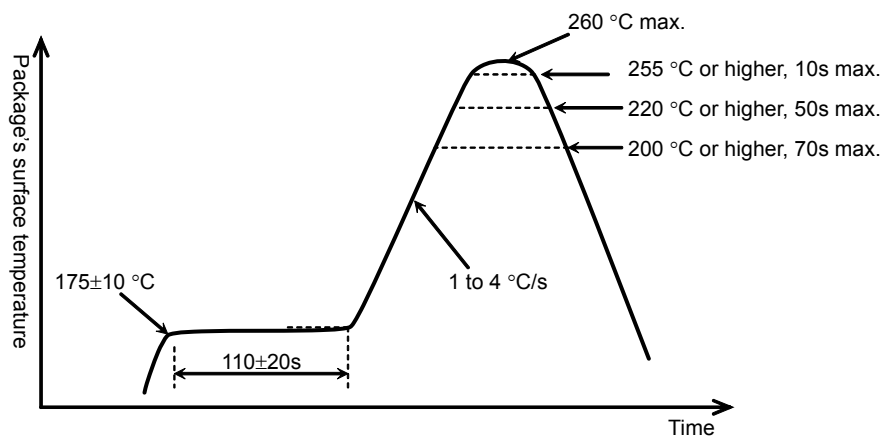

Figure 1: Infrared reflow, air reflow temperature profile

2. Soldering iron (Manual soldering)

Soldering bit's temperature: 370 °C or lower

Soldering time: Five seconds or less/terminal

9. Terminal Pin Specification

Base material	:Cu
Coat	:Sn-1.5%Cu
Thickness of coat	:5um or above

10. Cleaning

In case of cleaning boards with solvents after soldering, following items should be taken attention.

- *Administrative guidance and regulation.
- *Residual ionic (non ionic) contamination.
- *Solvent resistance of parts.

11.Changes and improvements

11-1. Version history

§ TSC-30/IC

Ver0.1 (July 31, 2007)

Draft release

Ver0.2 (September 27, 2007)

- 2. Pin layout Pin layout was changed. (SW0, SW1, LED0, LED2, RxD_I)
- 3. Pin functions Pin functions were changed. (LED0, LED2, USB_PW, EEP-DI/JP11, EEP-CLK/JP10, JP3, JP8)
- 4-2. Communication mode setting Terminal number was changed from 57 to 37.
- 4-5. Panel ID setting (USB mode) Replaced setting of JP4 with JP5.
- "6. Packing Specification" was added.
- "7. Storage Specification" was added.
- "8. Implementation Temperature Specification" was added.
- "9. Cleaning" was added.

Ver0.3 (November 29, 2007)

- 1-2. Outline 8-wire touch screen was added.
- 3. Pin function Pin functions were changed. (USBVref, USB_PW, JP6, JP7)
- 4-3. Touch screen mode setting 8-wire touch screen mode was added.
- 6-6. Product name label specification "Pb Free" was added.
- Circuit Diagram In USB mode, Vcc is 3.3V, it changed the circuit of the USB_PW terminal.
- Circuit Diagram A capacitor was added to a power I/F circuit.

Ver 1.0 (March 13, 2008)

First release

(Change from ver0.3.)

- 1-4. General specification Input response time was added.
- 2. Pin layout and representation Marking specification was changed.
- 3. Pin functions "8-wire" was added.
- 3. Pin functions "Sleep mode" was changed to "Power save mode".
- 4-2. Communication mode setting "Vcc" was changed to "USB Vbus".
- 5-2. Vibration frequency "In USB mode, Tolerance:±0.25%" was added.
- 9. Terminal Pin Specification was added.
- Circuit Diagram In USB mode, Self-powered mode was added.
- Circuit Diagram In USB mode, the part number of the resonator was changed.
- Circuit Diagram Revision 1 for first release.
- Document number was added.

12. Warranty

12-1. Warranty Period

- § The warranty period is limited to 1 year from the date of shipping. The warranty for the initial deflection such as appearance deflection is limited to 1 month.
- § Any defected parts under proper use will be examined by the supplier and replaced by the new parts if the deflection is considered to be caused by the supplier.
- § The replacement is subject to be included in the next lot.

12-2. Warranty Target

- § The warranty only covers the product itself and does not cover any damage to others caused by using this product. Onsite repair or replacement is not supported.
- § We will do our best for delivery problem and product defections, but the warranty for the production line is not covered.

12-3. Warranty Exceptions

Following conditions are not covered with the warranty and subject to charge.

- § Any malfunctions and damages during transportation and transfer by the user.
- § Any malfunctions and damages caused by a natural disaster or a fire.
- § Any malfunctions and damages caused by static electricity
- § Any malfunctions and damages caused by the failure of the associated equipment.
- § If the product is remodeled, disassembled or repaired by the user.
- § If the product is glued onto the equipment and uninstalled.
- § Any malfunctions and damages caused by an improper usage and handling against the specifications and notes.

13. Notes on use

13-1. Overall handling

- § When using the product, do not place it close to, or make it contact with, the conductive materials such as metal.
- § Do not touch the metal part in the product directly with your hands. Or, it may be destructed by the static electricity. If you contact, or may contact, it directly with your hand, prepare in advance the measure against static electricity.
- § To store the product, use an appropriate packing box and keep the storage temperature range with no overload on it.
- § In using the product or storing it, avoid the following conditions:
 - Conditions where water is, or may be, attached to the product.
 - Conditions where condensation takes place, or may take place.
 - In the ambience of organic solvent or acidity or contact, or where the product contacts them.
- § Do not alter or disassemble the product.

13-2. Others

- § This specification may be changed for improvement without prior notices.
- § No liabilities are taken by us for any damage caused by use of this product.
- § This product intends to be used for the standard applications (e.g. office equipment and OA devices, industrial use, communication devices, household equipment). Avoid its use where failure or malfunction directly may affect the human body or special applications where extremely high reliability is required (e.g. airline and space industries, nuclear controls, medical use for life-sustaining).
- § Semi-conductor devices may fail in a certain possibility. Keep the safety design in your mind so that possible failure in this product shall not cause physical accidents such as injury and death, fire and other social damages.

TSC-30/IC Product Specification
Version 1.0: Issued at March 13, 2008
©2008 DMC Co., Ltd.

This document is allowed to redistribute but no alteration, part or all, is prohibited.

DMC Co., Ltd.

<http://www.dmccoltd.com/english/>
9F Kanda Sent-Building 1-2-4, Yushima, Bunkyo-ku, Tokyo, 113-0034 Japan
Phone: +81-3-5209-7131 (Japanese), 7135 (English) Fax: +82-3-5209-7130

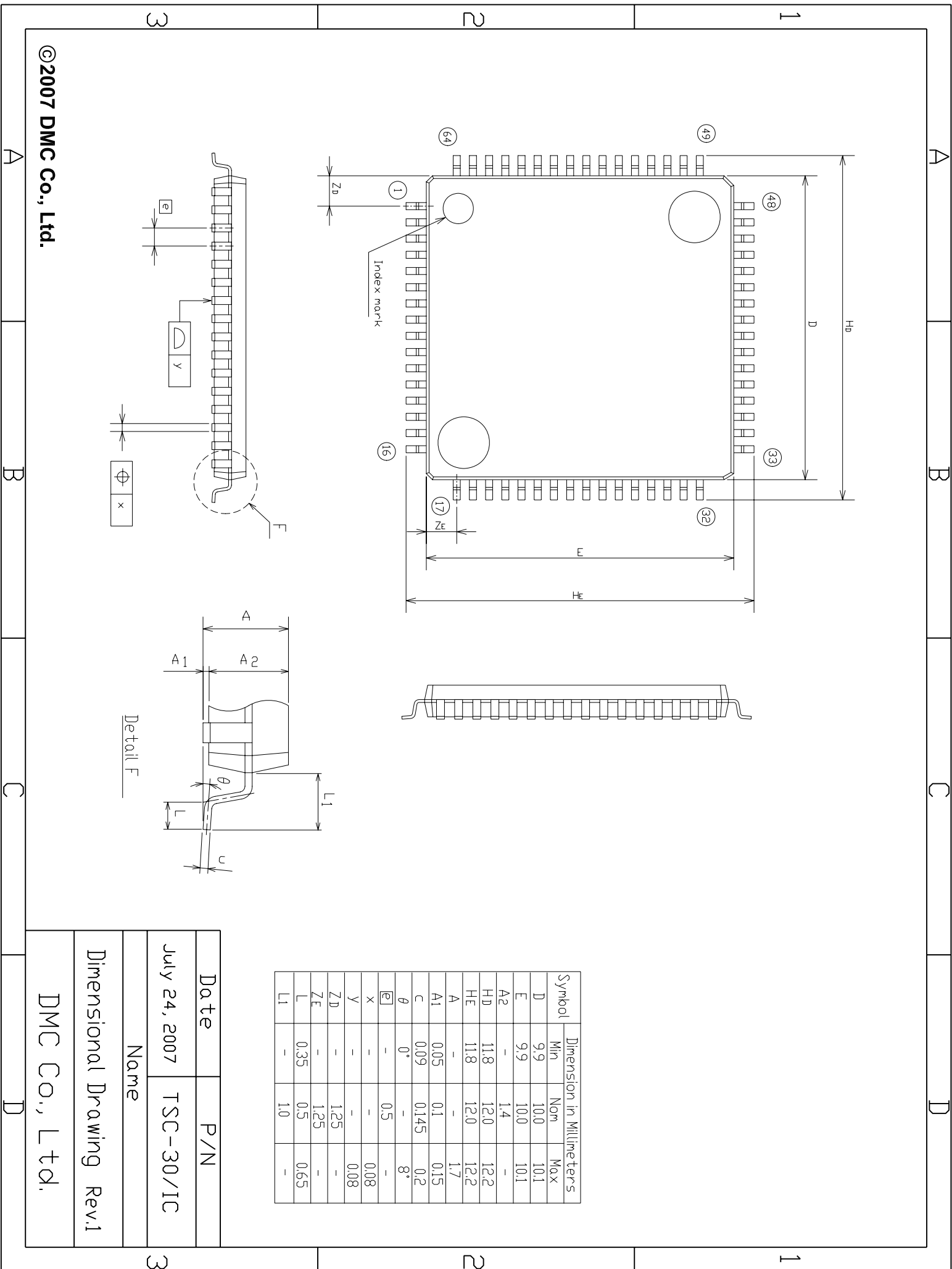

Symbol	Dimension in Millimeters		
	Min	Nom	Max
D	9.9	10.0	10.1
E	9.9	10.0	10.1
A2	-	1.4	-
Hd	11.8	12.0	12.2
HE	11.8	12.0	12.2
A	-	-	1.7
A1	0.05	0.1	0.15
C	0.09	0.145	0.2
θ	0°	-	8°
e	-	0.5	-
x	-	-	0.08
y	-	-	0.08
ZD	-	1.25	-
ZE	-	1.25	-
L	0.35	0.5	0.65
L1	-	1.0	-

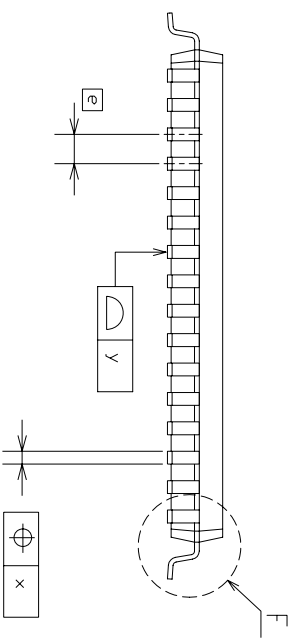
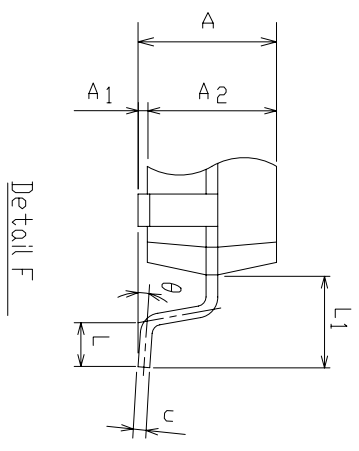

©2007 DMC Co., Ltd.

Date	July 24, 2007	P/N	TSC-30/IC
Name	Dimensional Drawing Rev.1		
DMC Co., Ltd.			

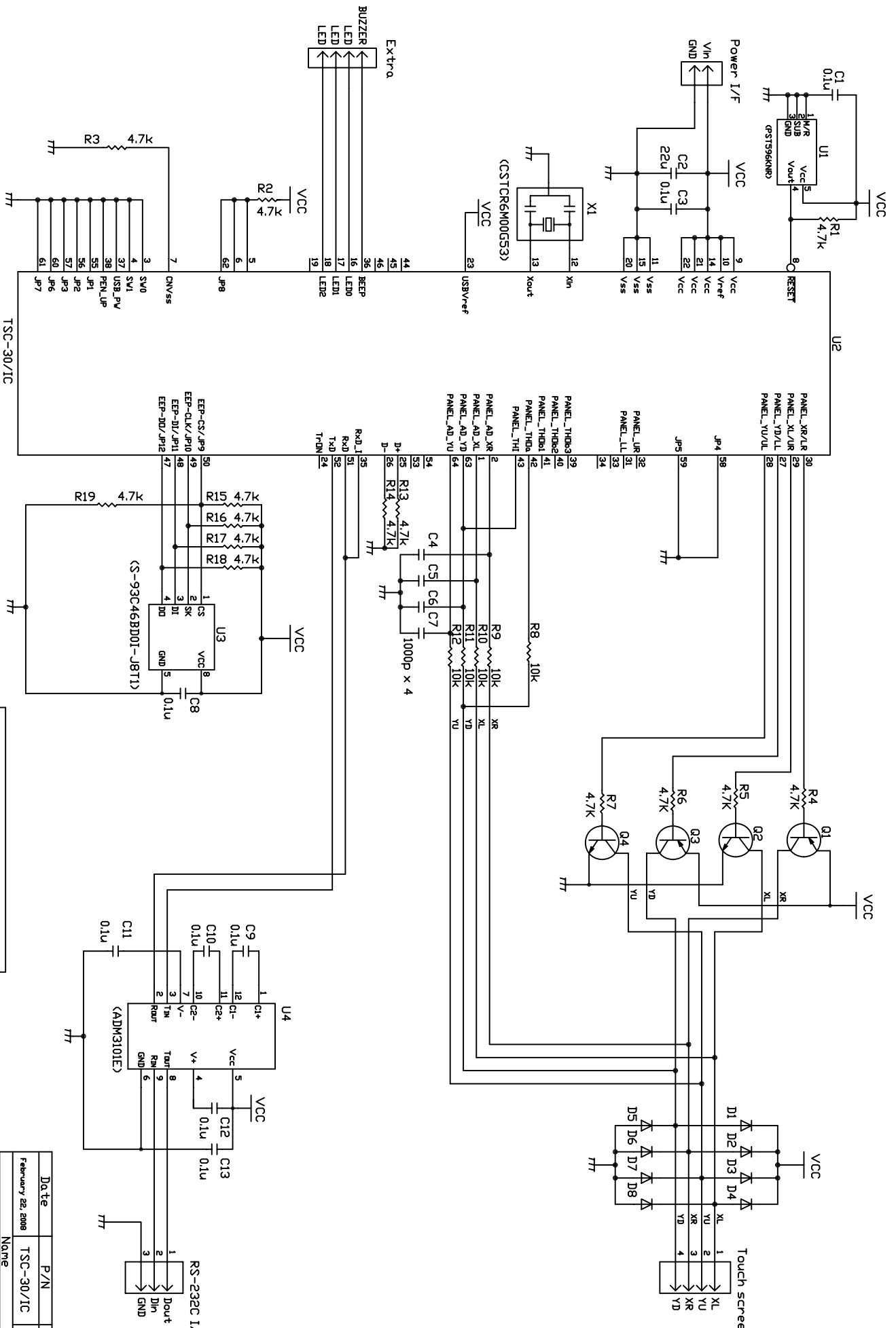

With EEPROM : Delete R15, R16, R17
 Without EEPROM : Delete R19, U3, C8

TSC-30/1C

RS-232C I/F

ADM3101E

RS-232C I/F

Extra

Buzzer

LED

LED

LED

LED

BEEP

LED0

LED1

LED2

LED3

USB+ref

USB-vef

Xout

Xin

Xout

Vcc

Vref

Vcc

Vcc

Vcc

Vcc

Vcc

Vcc

Vcc

Vcc

Vcc

Vcc

Vcc

Vcc

Vcc

Vcc

Vcc

Vcc

Vcc

Vcc

Vcc

© DMC Co., Ltd.

This document is to be used as a reference guide only. DMC assumes no liability for applications assistance or customer product design. DMC does not warrant or represent that any license is granted under patent or other rights.

February 22, 2008

TSC-30/1C

4-Wire Resistive Touch Screen RS-232C I/F Circuit Diagram

DMC Co., Ltd.

Date

P/N

Rev.

1

1

1

1

1

1

1

1

1

1

1

1

1

1

1

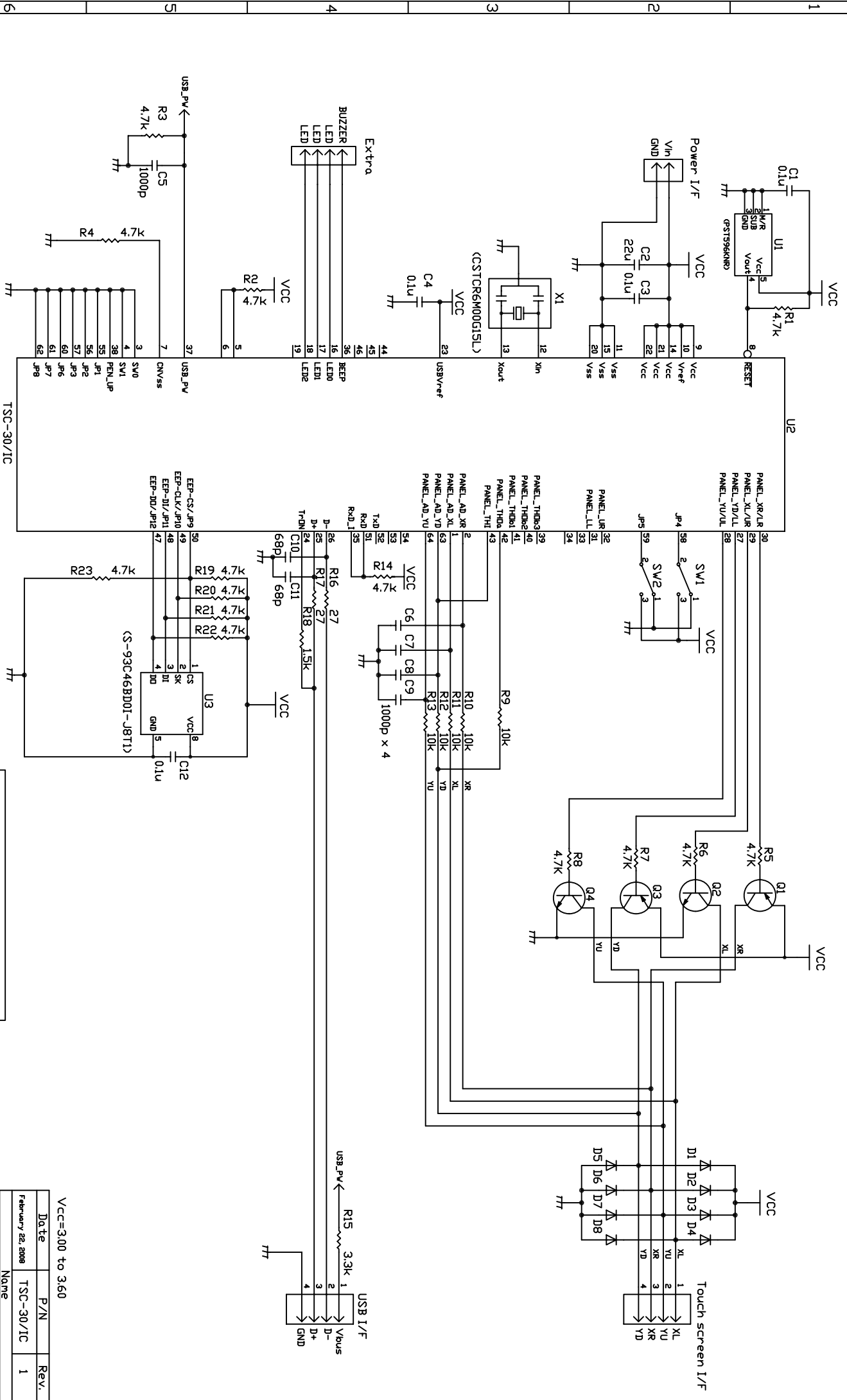

© DMC Co., Ltd.
 This document is to be used as a reference guide only. customer product design.
 DMC assumes no liability for applications assistance or representations that only license is granted under patent or other rights.

With EEPROM : Delete R19, R20, R21
 Without EEPROM : Delete R23, U3, C12

VCC=3.00 to 3.60

Date	P/N	Rev.
February 22, 2008	TSC-30/IC	1

4-Wire Resistive Touch Screen
 USB I/F Circuit Diagram

DMC Co., Ltd.

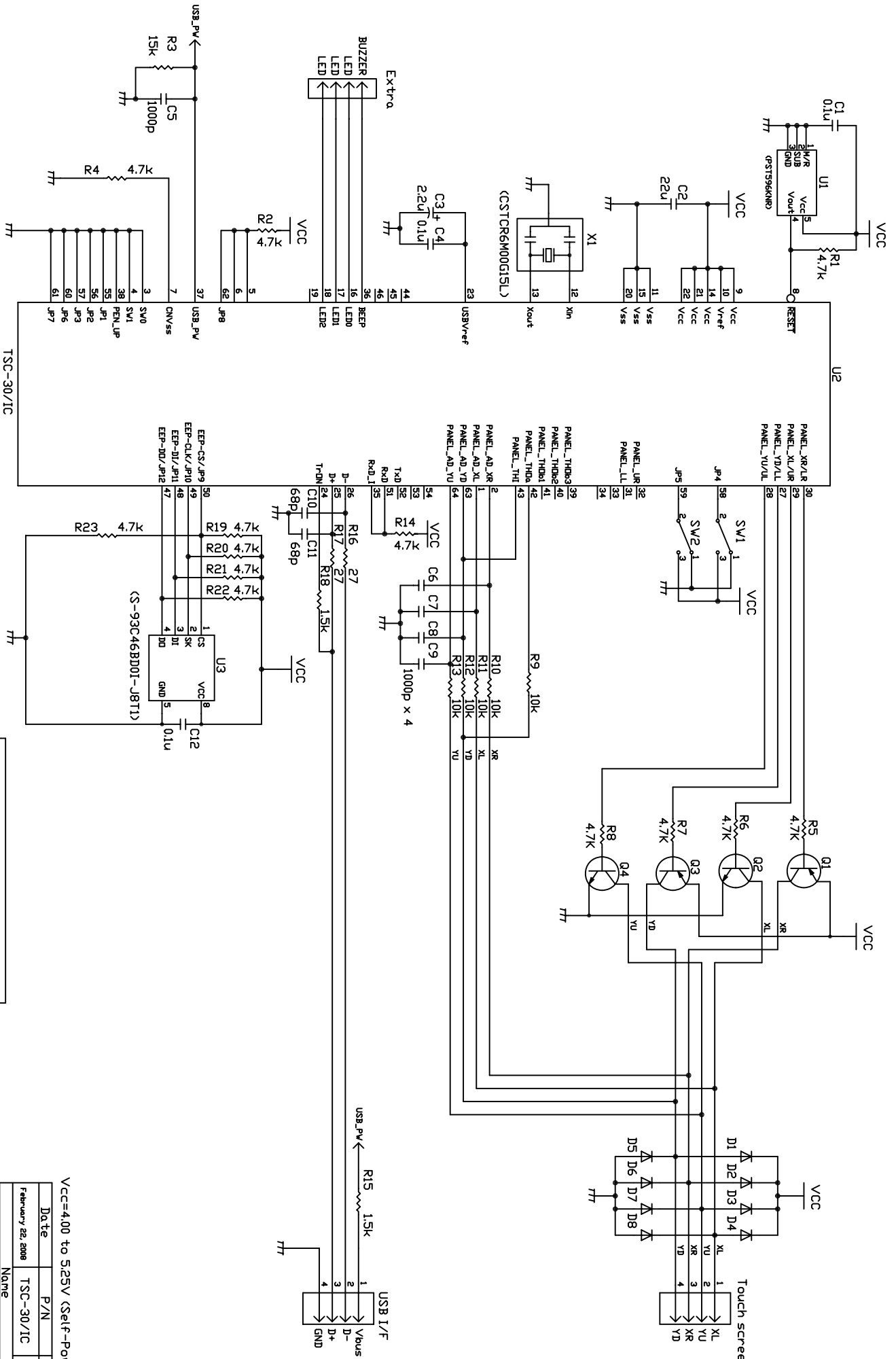

TSC-30/IC

(S-93C46BD01-J8T1)

(CSTOR6M00G15L)

(S-93C46BD01-J8T1)

With EERRDM : Delete R19, R20, R21
 Without EERRDM : Delete R23, U3, C12

VCC=4.00 to 5.25V (Self-Powered)

Date	P/N	Rev.
February 22, 2008	TSC-30/IC	1

4-Wire Resistive Touch Screen
 USB I/F Circuit Diagram

DMC Co., Ltd.

© DMC Co., Ltd.

This document is to be used as a reference guide only. Customer product design. DMC assumes no liability for applications assistance or representations that only license is granted under patent or other rights.

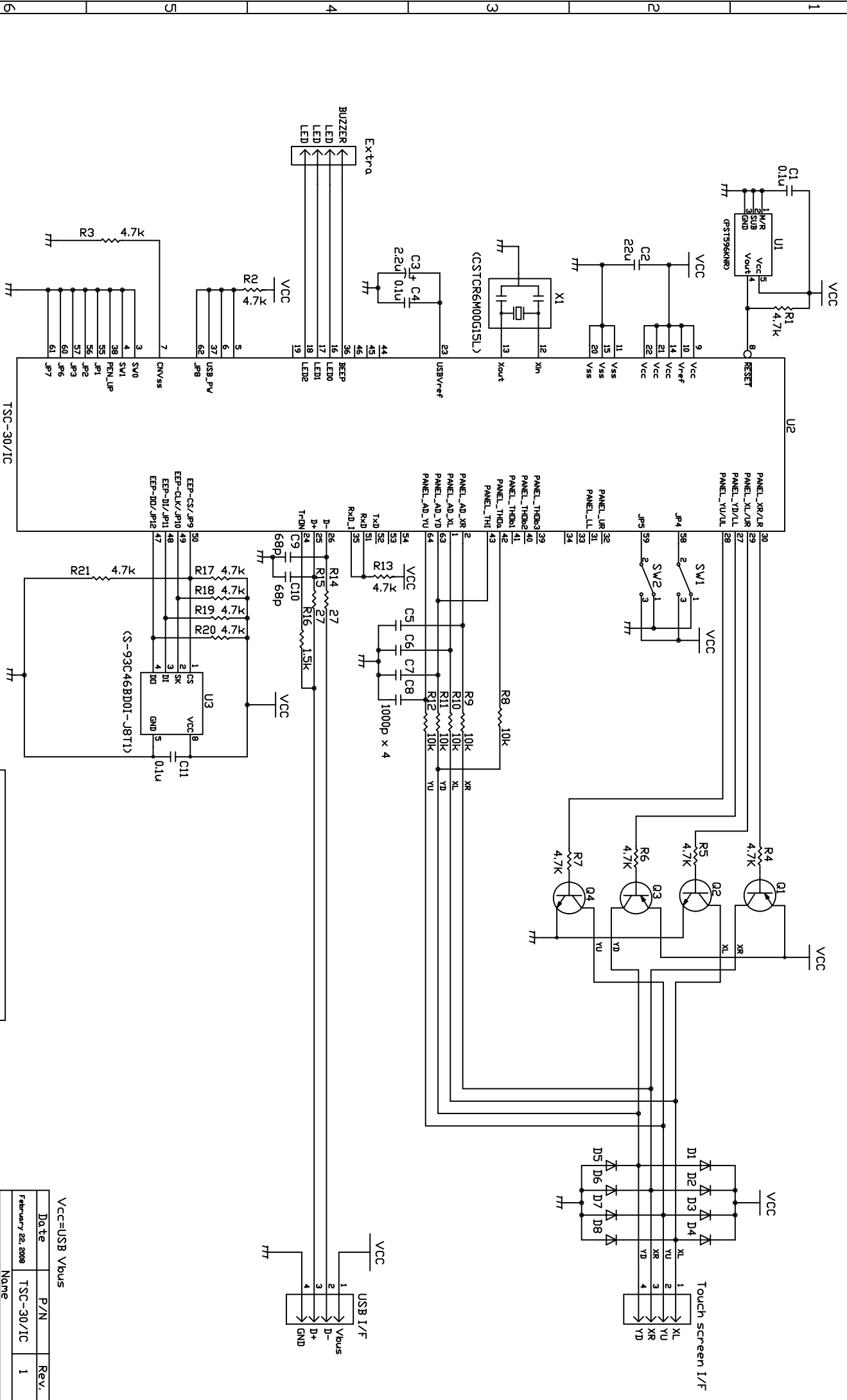

With EEPFRDM : Delete R17, R18, R19
 Without EEPFRDM : Delete R21, U3, C11

TSC-30/1C

VCC=USB Vbus

Date	P/N	Rev.
February 22, 2008	TSC-30/1C	1

4-Wire Resistive Touch Screen
 USB I/F Circuit Diagram

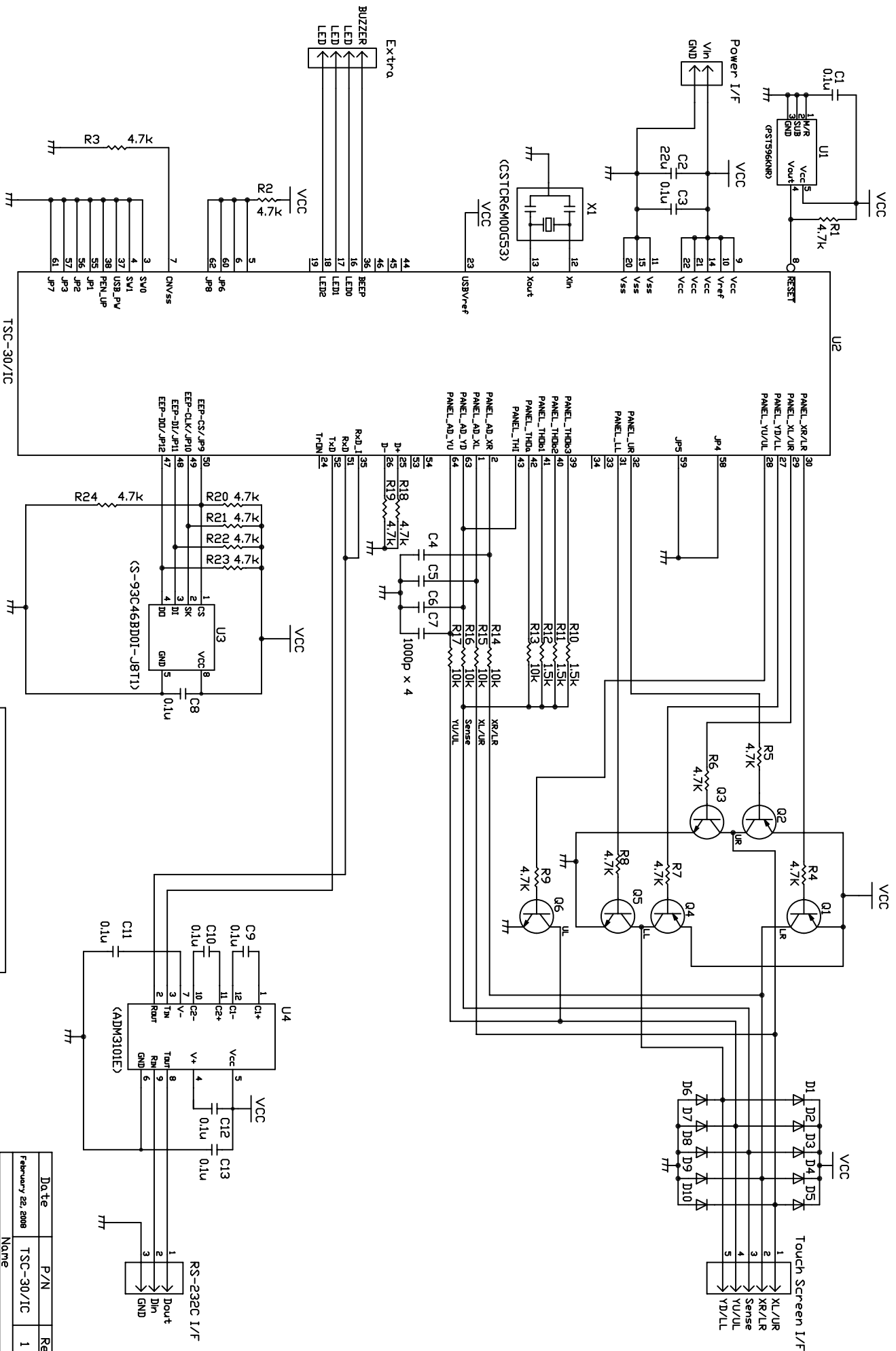

This document is to be used as a reference guide only. DMC assumes no liability for applications assistance or customer product design. DMC does not warrant or represent that any license is granted under patents or other rights.

With EERRDM : Delete R20, R21, R22
 Without EERRDM : Delete R24, U3, C8

Date	P/N	Rev.
February 22, 2008	TSC-30/1C	1
Name		
S-Wire Resistive Touch Screen		
RS-232C I/F Circuit Diagram		
DMC Co., Ltd.		

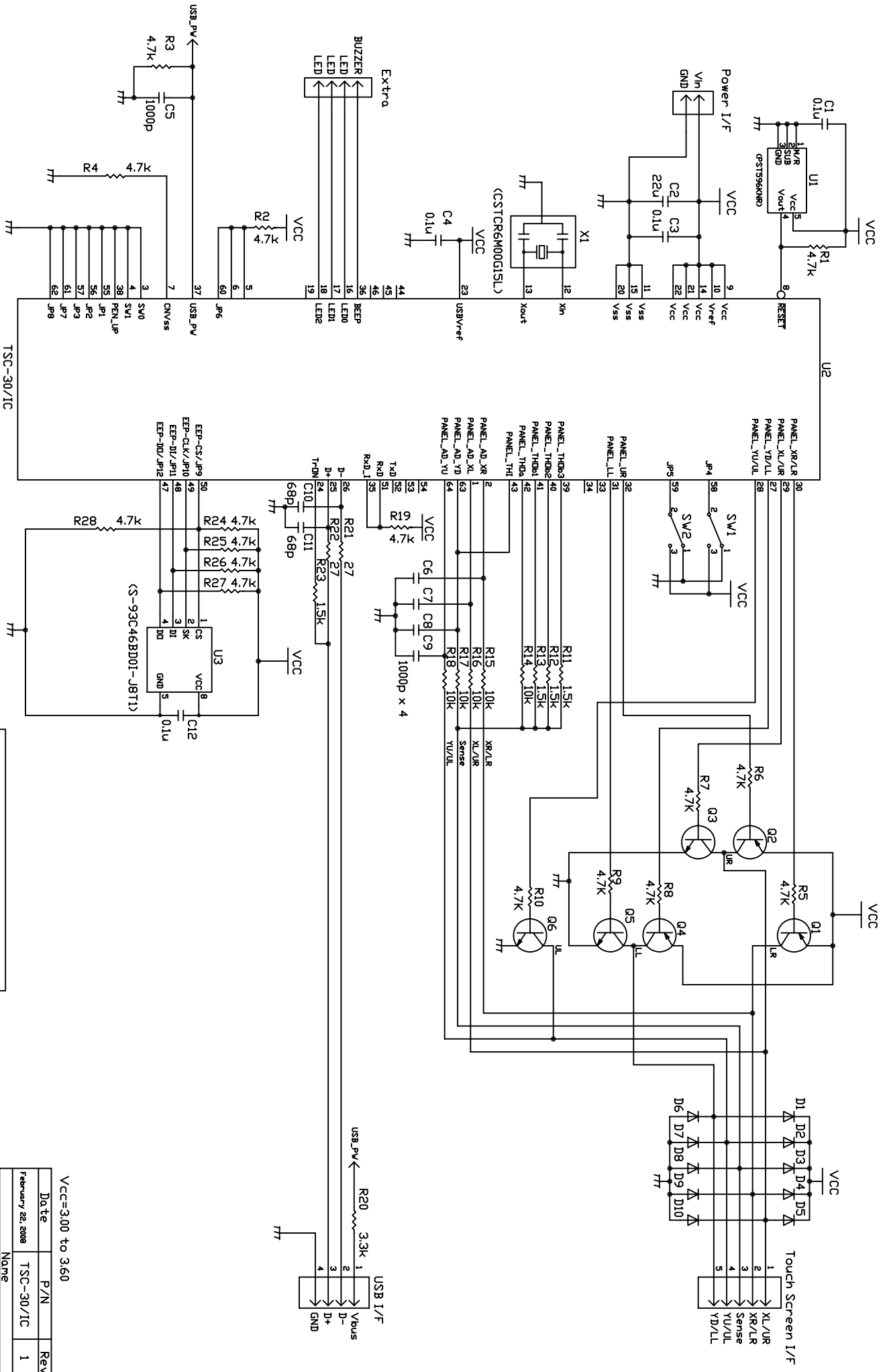

TSC-30/IC

(S-93C46BD01-J8T1)

(CSTCR6M00G15L)

Without EERRDM : Delete R24, R25, R26
 Without EERRDM : Delete R28, U3, C12

VCC=3.00 to 3.60

Date	P/N	Rev.
February 22, 2008	TSC-30/IC	1

5-Wire Resistive Touch Screen
 USB I/F Circuit Diagram

DMC Co., Ltd.

© DMC Co., Ltd.
 This document is to be used as a reference guide only. customer product design.
 DMC assumes no liability for applications assistance or representations that only license is granted under patent or other rights.

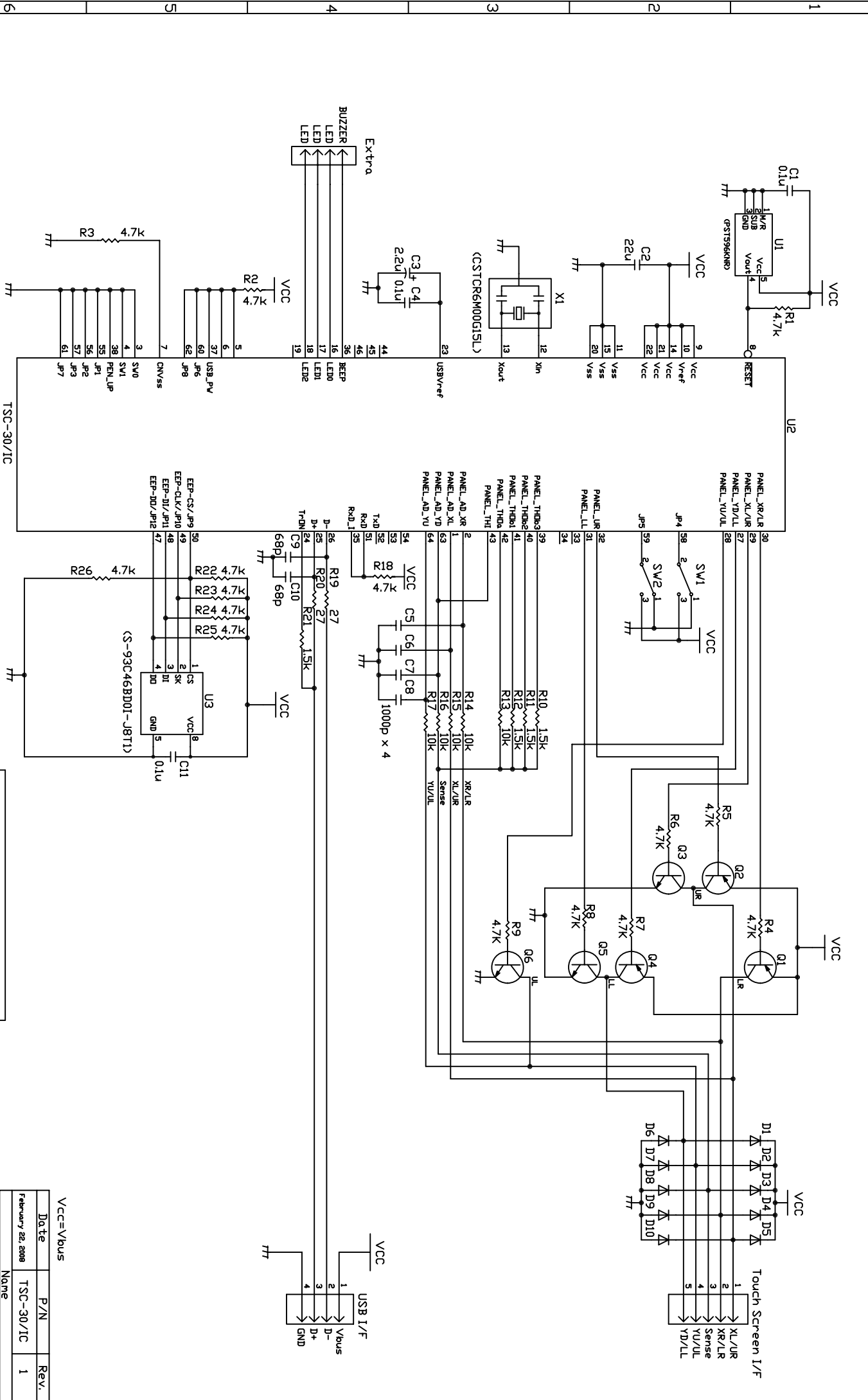

© DMC Co., Ltd.

This document is to be used as a reference guide only. Customer product design. DMC assumes no liability for applications assistance or representations that only license is granted under patent or other rights.

Date	P/N	Rev.
February 22, 2008	TSC-30/IC	1

VCC=Vbus

Without EEPROM : Delete R22, R23, R24
 Without EEPROM : Delete R26, U3, C11

5-Wire Resistive Touch Screen
 USB I/F Circuit Diagram

DMC Co., Ltd.

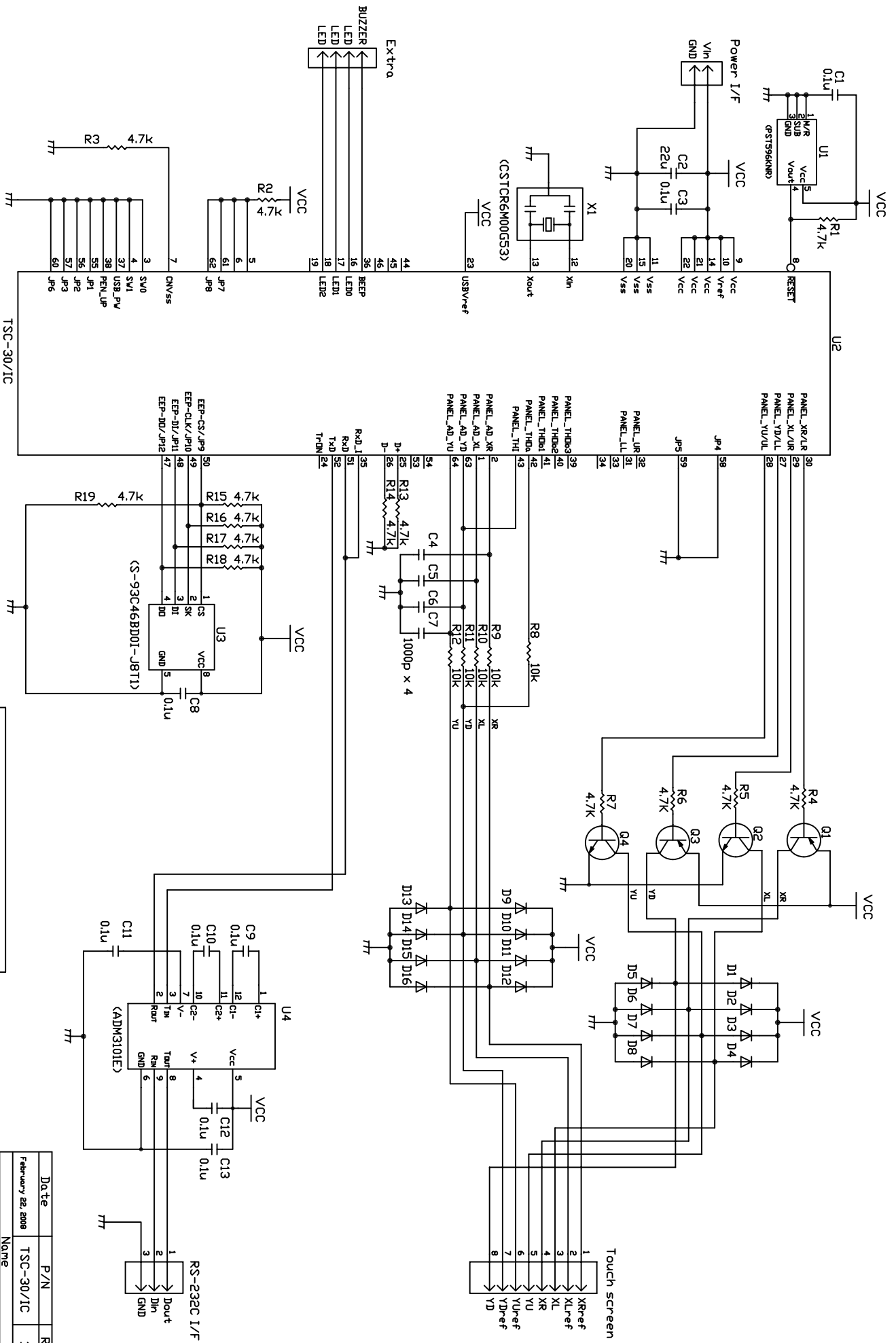

With EEPROM : Delete R15, R16, R17
 Without EEPROM : Delete R19, U3, C8

Extra
 BUZZER
 LED
 LED
 LED

© DMC Co., Ltd.
 This document is to be used as a reference guide only. customer product design.
 DMC assumes no liability for applications assistance or representations that only license is granted under patent or other rights.

Date	P/N	Rev.
February 22, 2008	TSC-30/1C	1

Name: 8-Wire Resistive Touch Screen
 RS-232C I/F Circuit Diagram

DMC Co., Ltd.

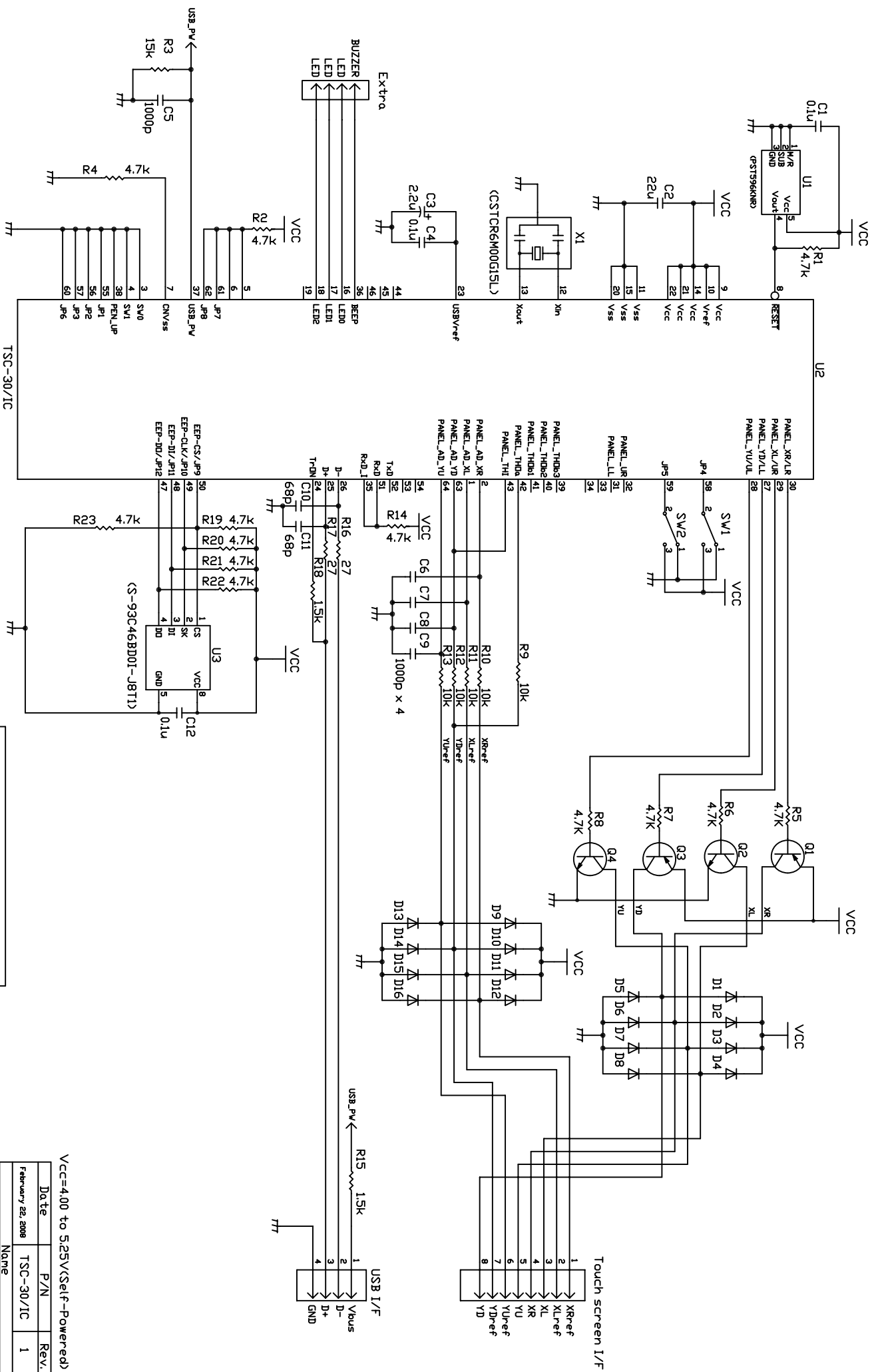

TSC-30/1C

Touch screen I/F

USB I/F

VCC=4.00 to 5.25V(Self-Powered)

Date	P/N	Rev.
February 22, 2008	TSC-30/1C	1

8-Wire Resistive Touch Screen
USB I/F Circuit Diagram

DMC Co., Ltd.

With EEPROM : Delete R19, R20, R21
Without EEPROM : Delete R23, U3, C12

This document is to be used as a reference guide only. Customer product design. DMC assumes no liability for applications assistance or representations that only license is granted under patents or other rights.

© DMC Co., Ltd.

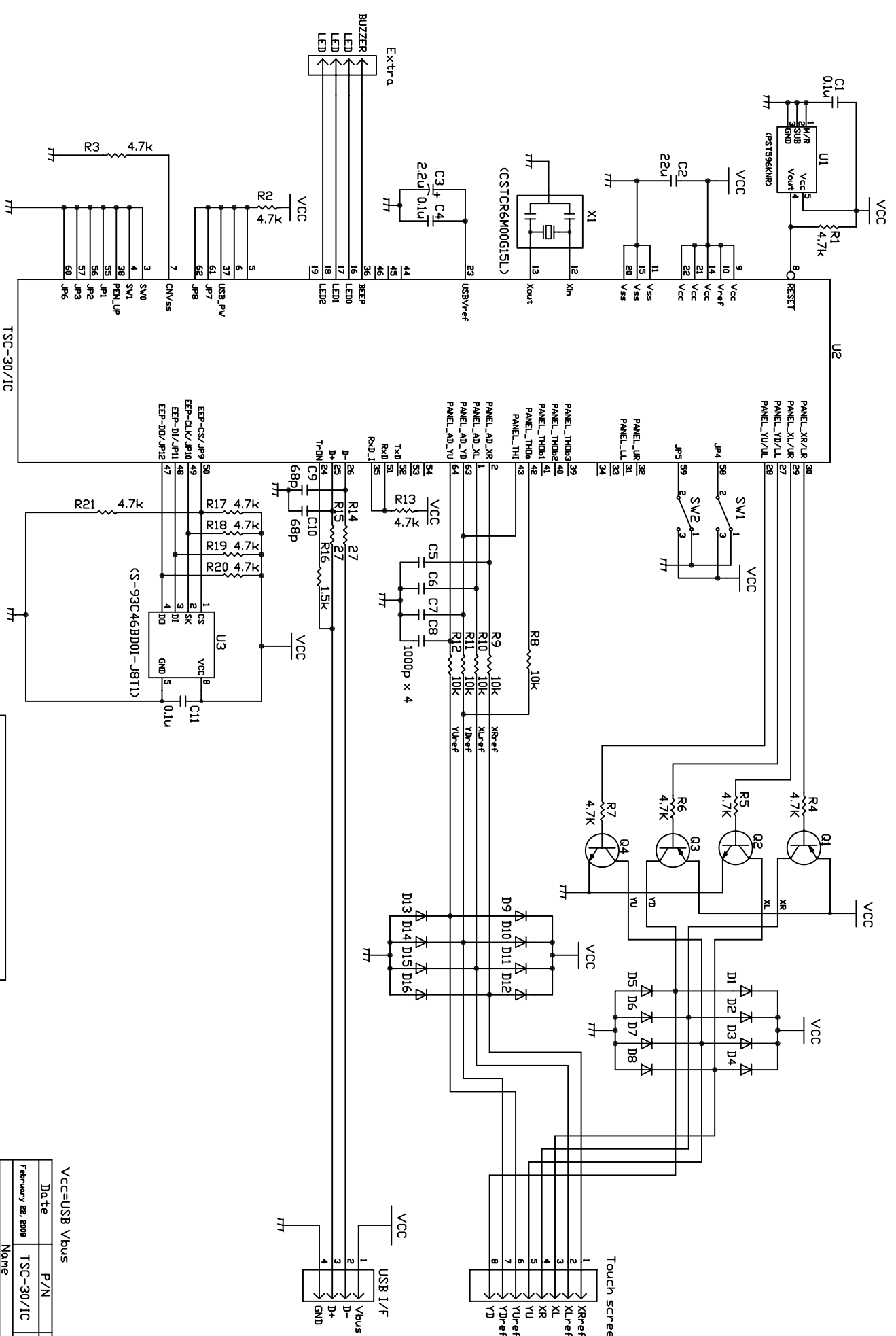

With EERRDM : Delete R17, R18, R19
 Without EERRDM : Delete R21, U3, C11

Vcc=USB Vbus

Date	P/N	Rev.
February 22, 2008	TSC-30/1C	1

8-Wire Resistive Touch Screen
 USB I/F Circuit Diagram
 DMC Co., Ltd.